

---

***IGLOO2 HPMS***  
***Services Configuration***



---

# Table of Contents

---

Configuration Options .....	3
Configuration .....	3
<b>A Product Support .....</b>	<b>5</b>
Customer Service .....	5
Customer Technical Support Center .....	5
Technical Support .....	5
Website .....	5
Contacting the Customer Technical Support Center .....	5
ITAR Technical Support .....	6



- In SmartDesign, instantiate and configure the CoreSysServices IP core, and connect it to this exposed port (Figure 2). The CoreSysServices is an IP core available from the Catalog.

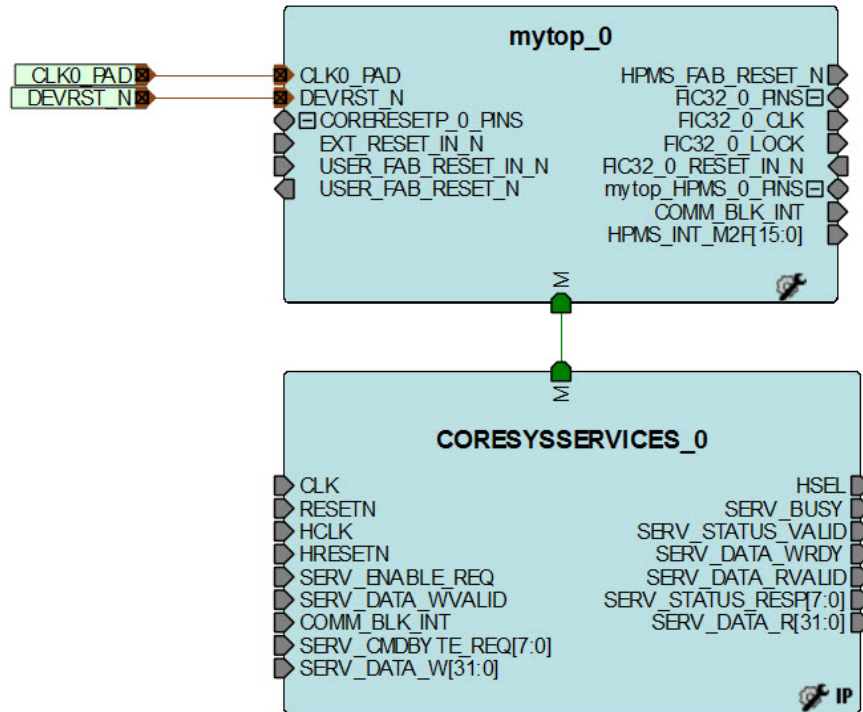

**Figure 2 • CoreSysServices IP Core Connected to Master Port of System Builder Generated Block**

The CoreSysServices IP Core is part of the FIC\_0 Subsystem and is accessible from IGLOO2 HPMS via the FIC\_0 Bus Interface, as shown in Figure 3

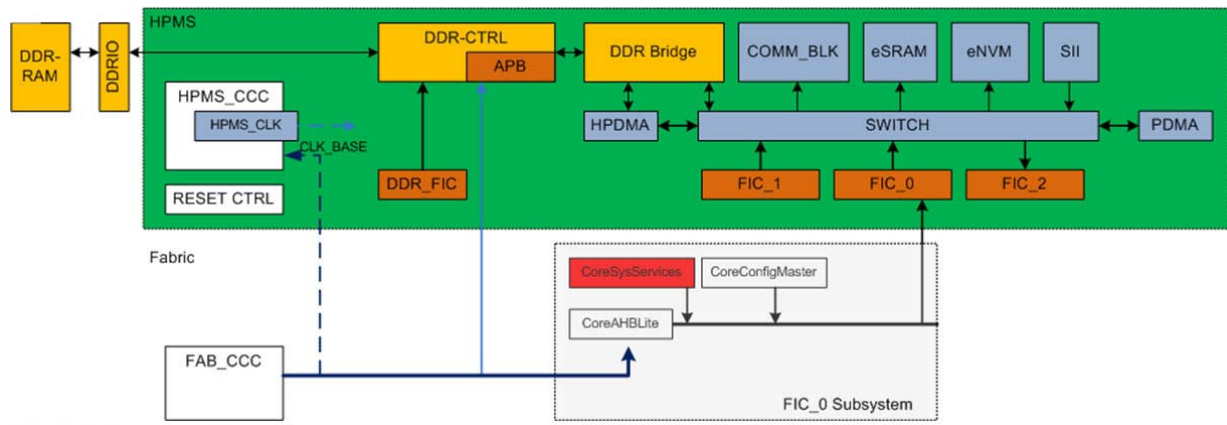

**Figure 3 • CoreSysServices IP Core Included in FIC\_0 Subsystem**

---

## A – Product Support

---

Microsemi SoC Products Group backs its products with various support services, including Customer Service, Customer Technical Support Center, a website, electronic mail, and worldwide sales offices. This appendix contains information about contacting Microsemi SoC Products Group and using these support services.

### Customer Service

Contact Customer Service for non-technical product support, such as product pricing, product upgrades, update information, order status, and authorization.

From North America, call 800.262.1060

From the rest of the world, call 650.318.4460

Fax, from anywhere in the world, 408.643.6913

### Customer Technical Support Center

Microsemi SoC Products Group staffs its Customer Technical Support Center with highly skilled engineers who can help answer your hardware, software, and design questions about Microsemi SoC Products. The Customer Technical Support Center spends a great deal of time creating application notes, answers to common design cycle questions, documentation of known issues, and various FAQs. So, before you contact us, please visit our online resources. It is very likely we have already answered your questions.

### Technical Support

Visit the Customer Support website ([www.microsemi.com/soc/support/search/default.aspx](http://www.microsemi.com/soc/support/search/default.aspx)) for more information and support. Many answers available on the searchable web resource include diagrams, illustrations, and links to other resources on the website.

### Website

You can browse a variety of technical and non-technical information on the SoC home page, at [www.microsemi.com/soc](http://www.microsemi.com/soc).

### Contacting the Customer Technical Support Center

Highly skilled engineers staff the Technical Support Center. The Technical Support Center can be contacted by email or through the Microsemi SoC Products Group website.

#### Email

You can communicate your technical questions to our email address and receive answers back by email, fax, or phone. Also, if you have design problems, you can email your design files to receive assistance. We constantly monitor the email account throughout the day. When sending your request to us, please be sure to include your full name, company name, and your contact information for efficient processing of your request.

The technical support email address is [soc\\_tech@microsemi.com](mailto:soc_tech@microsemi.com).

## My Cases

Microsemi SoC Products Group customers may submit and track technical cases online by going to [My Cases](#).

## Outside the U.S.

Customers needing assistance outside the US time zones can either contact technical support via email ([soc\\_tech@microsemi.com](mailto:soc_tech@microsemi.com)) or contact a local sales office. [Sales office listings](#) can be found at [www.microsemi.com/soc/company/contact/default.aspx](http://www.microsemi.com/soc/company/contact/default.aspx).

## ITAR Technical Support

For technical support on RH and RT FPGAs that are regulated by International Traffic in Arms Regulations (ITAR), contact us via [soc\\_tech\\_itar@microsemi.com](mailto:soc_tech_itar@microsemi.com). Alternatively, within [My Cases](#), select **Yes** in the ITAR drop-down list. For a complete list of ITAR-regulated Microsemi FPGAs, visit the [ITAR](#) web page.



**Microsemi**

**Microsemi Corporate Headquarters**  
One Enterprise, Aliso Viejo CA 92656 USA  
Within the USA: +1 (949) 380-6100  
Sales: +1 (949) 380-6136  
Fax: +1 (949) 215-4996

Microsemi Corporation (NASDAQ: MSCC) offers a comprehensive portfolio of semiconductor solutions for: aerospace, defense and security; enterprise and communications; and industrial and alternative energy markets. Products include high-performance, high-reliability analog and RF devices, mixed signal and RF integrated circuits, customizable SoCs, FPGAs, and complete subsystems. Microsemi is headquartered in Aliso Viejo, Calif. Learn more at [www.microsemi.com](http://www.microsemi.com).

© 2013 Microsemi Corporation. All rights reserved. Microsemi and the Microsemi logo are trademarks of Microsemi Corporation. All other trademarks and service marks are the property of their respective owners.